

Model

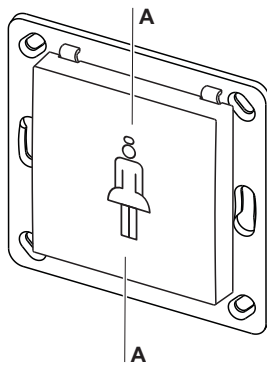

RTS22E5001A04 CALL 1 button operation

Technical Details

Frequency:	868.3 MHz
Radiated power:	1.29 mW
Modulation:	FSK
Coding:	Easywave (A)
Power supply:	1x 3-V-battery, CR2032
Operating Temperature:	-20 °C to +60 °C
Range:	free-field: approx. 150 m buildings: approx. 30 m
Dimensions:	Button: 55x55x10 mm Plate: 71x71x1,5 mm
Weight:	34.0 g incl. battery

Scope of Delivery

Transmission module incl. battery CR2032, mounting plate, button, attachment set, operating instructions

Intended Use

Only use the Radio Wall Switch RTS22 in dry indoor rooms to switch Easywave receivers. The manufacturer shall not be liable for any damage caused by improper or non-intended use.

Safety Advice



Before using the Radio Wall Switch, carefully read through the operating instructions!

Also note the operating instructions of the receiver(s)!

The Radio Wall Switch should only be operated within sight of the devices to be controlled! Otherwise persons could be placed in danger!

Have faulty Radio Wall Switches checked by the manufacturer!

Do not make any unauthorized alterations or modifications to the Radio Wall Switch!

Keep the batteries out of the reach of children!

Function

The RTS22 CALL is a wireless switch transmitter for surface mounting in dry rooms. It fits into the most of switch frames with the dimensions of 55x55 mm.

By pushing the button the Easywave code A is transmitted and the connected Easywave receivers are switched in their selected operating mode.

With the learning button **PTx** you can bring an Easywave radio receiver into the programming mode. This requires that the receiver supports this feature. Please read the operating instructions supplied with the receivers.

Start-Up

1. Screw or stick the mounting plate to the installation site with the screws and dowels or the adhesive pads.

Caution: Make sure there is no interference with the wireless connection. Do not mount the device in a distribution box, in metal casings, in direct proximity to large metal objects, on the floor or close to it.

2. Place the cover frame onto the mounting plate and snap the transmission module to the catches on top and bottom. The arrow on the transmission module has to point upwards.

3. Snap the button onto the transmission module.

4. Memorize the transmission code in the receivers. Please read the operating instructions supplied with the receivers.

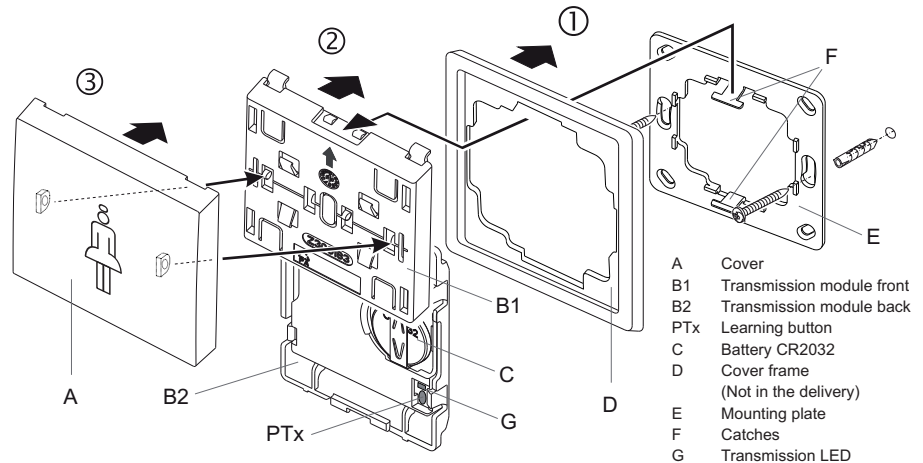

Replacing the Battery

1. Lever off the transmission group.
2. Replace the battery. Only use batteries of the type CR2032. **Make sure the poling is correct. The positive pole has to be visible!**
3. Replace the transmission group back onto the catches.

Note: The coding of the transmitter is preserved even if there is no voltage supply. You do not need to memorize the code in the receivers again after a battery change.

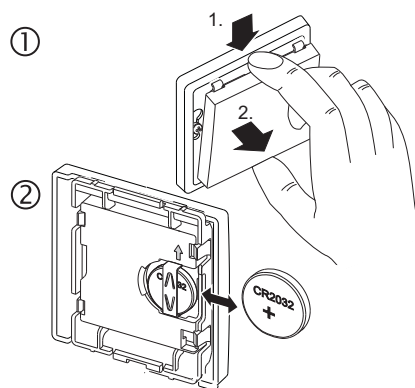

Disposal

Waste electrical products and batteries not be disposed of with household waste!

Dispose of the waste product via a collection point for electronic scrap or via your specialist dealer.

Dispose of used batteries in a recycling bin for batteries or via the specialist trade.

Put the packaging material into the recycling bins for cardboard, paper and plastics.



Warranty

Within the statutory warranty period we undertake to rectify free of charge by repair or replacement any product defects arising from material or production faults.

Any unauthorized tampering with, or modifications to, the product shall render this warranty null and void.

Conformity

Hereby, ELDAT EaS GmbH declares that the radio equipment type RTS22 is in compliance with Directive 2014/53/EU.



The full text of the EU declaration of conformity is available at the following internet address: www.eldat.de

Service

If, despite correct handling, faults or malfunctions occur or if the product was damaged, please contact the company at the address below:

ELDAT EaS GmbH
Schmiedestraße 2

15745 Wildau
Germany

Phone: + 49 (0) 33 75 / 90 37-310

Fax: + 49 (0) 33 75 / 90 37-90

Internet: www.eldat.de

E-Mail: info@eldat.de

Trouble Shooting

If the radio control does not react to the Radio Wall Switch:

- Exchange the battery.
- Check that the wireless connection at the installation site is not impaired between the Radio Wall Switch and the receiver.
- Memorize the transmission code in the receiver.
- Other wireless devices using the same frequency or working in direct proximity may interfere with the device.